

POLE SHAFT SPECIFICATIONS				
1. SHAFTS ARE ONE SECTION DESIGN FABRICATED FROM 6063 T6 ALUMINUM EXTRUSION-SPUN TAPERED.				
2. BASE CASTING IS 356 T6 ALUMINUM. THE SHAFT TELESOPES INTO THE BASE CASTING AND IS CIRCUMFERENTIALLY WELDED TOP AND BOTTOM.				
3. ANCHOR BOLTS ARE 1" FORMED RODS HAVING A MINIMUM YIELD STRENGTH OF 55,000 P.S.I. FABRICATED FROM ASTM F1554 GR. 55 THEN PARTIALLY GALVANIZED PER ASTM A153 SPECIFICATIONS AND FURNISHED COMPLETE WITH 2 HEX NUTS AND 2 FLAT WASHERS.				
4. POLES SHALL HAVE A POLYESTER POWDER COAT FINISH IN A STANDARD COLOR.				
POLE DIMENSIONS				
POLE HGT. (FT.)	TOP DIA. (IN.)	BOTTOM DIA. (IN.)	GAGE	MTG. HGT. (FT.)
18'	4.50	7.00	.156	20'
BASE PLATE DIMENSIONS				
BOLT CIRCLE (IN.)	BASE PLATE DIM. (IN.)	BOLT HOLE (IN.)	PLATE THK. (IN.)	
10.00-11.00	11.28 SQ	1.13	1.00	
ANCHOR BOLT DIMENSIONS				
ANCHOR BOLT DIA. (IN.)		ANCHOR BOLT LENGTH (IN.)		
1.00		40.00		
ALLOWABLE WIND LOADING (SQ. FT.) PER ARM				
WIND*		100 MPH		
EPA		2.0		

*WITH 1.3 GUST FACTOR

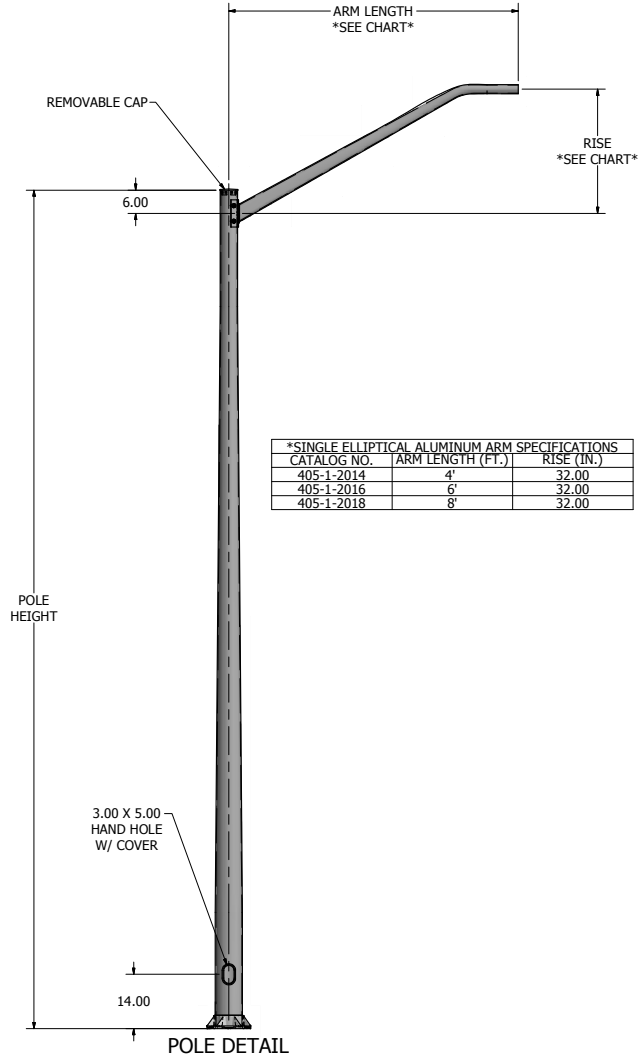

*SINGLE ELLIPTICAL ALUMINUM ARM SPECIFICATIONS		
CATALOG NO.	ARM LENGTH (FT.)	RISE (IN.)
405-1-2014	4'	32.00
405-1-2016	6'	32.00
405-1-2018	8'	32.00

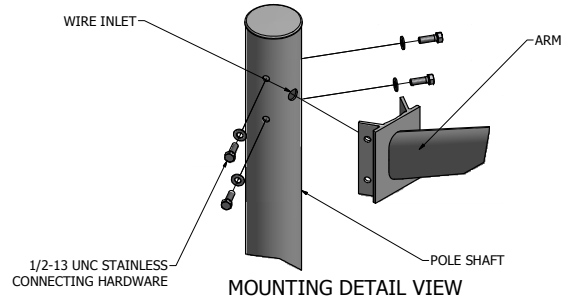
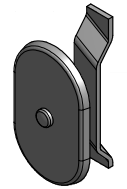

3.00 X 5.00 HAND HOLE COVER

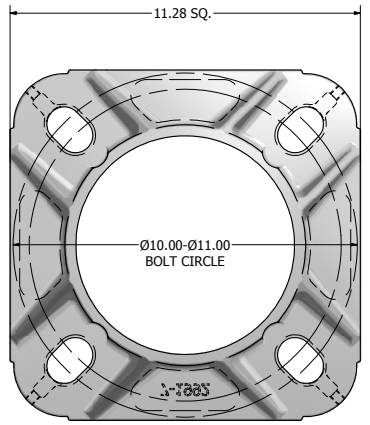

11.28 X 11.28 X 3.38 THK. BASE CASTING

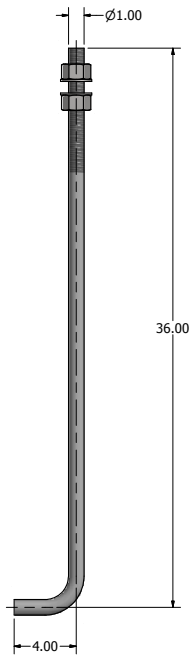

Ø1.00 X 40.00 ANCHOR BOLT

lyte poles
a DSW company

P.O. Box 340
Eastpointe, MI 48021
P: (586) 771-4610 | F: (586) 771-5527
www.lytepoles.com

DRAWN: M. HARVALA	2/16/2015	SOME GEOGRAPHICAL AREAS HAVE SPECIAL WIND CONDITIONS THAT CAN CREATE WIND INDUCED VIBRATIONS CAUSING A FATIGUE PROBLEM. NO METHOD HAS YET BEEN FOUND FOR PREDICTING DESTRUCTIVE LIGHTING POLE VIBRATION. THESE CONDITIONS ARE UNIQUE AND CANNOT BE GUARANTEED AGAINST, AND ARE THE RESPONSIBILITY OF A LOCAL SITE ENGINEER.	
CHECKED:	DATE:		
REVISION:	DATE:		
APPROVED:			
QUOTE:			
S.O.#		TITLE:	
REF:	SCALE: NONE	CATALOG:	
		DWG NO: 405-1-2014-405-1-2018	SIZE D
		SHEET 1 OF 1	